

7 | 07 14 00
 Fluid-Applied
 Waterproofing

MasterSeal® HLM 5000

Liquid, cold-applied elastomeric waterproofing membrane system

FORMERLY SONOSHIELD® HLM 5000

YIELD

25–30 ft²/gal at 55–65 wet mils
 (0.61–0.74 m²/L at 1.4–1.7 mm wet thickness)

25–30 ft²/gal at 45–55 dry mils
 (0.61–0.74 m²/L at 1.1–1.4 mm dry thickness)

Coverage may vary with the application technique used. Actual coverage rate and mil thickness depend on finish and porosity of the substrate.

STORAGE

Store in unopened containers in clean, dry conditions at 40 to 80 °F (4 to 27 °C). During storage, an easily removed skin of HLM 5000 may form, which does not affect performance of the product.

SHELF LIFE

- 1 Year Pails
- 6 Months Drums

VOC CONTENT

- MasterSeal HLM 5000 SL: 183 g/L
- MasterSeal HLM 5000 S: 190 g/L
- MasterSeal HLM 5000 R: 180 g/L
- MasterSeal HLM 5000 T: 132 g/L

DESCRIPTION

MasterSeal HLM 5000 is a one-component, moisture-curing, bitumen-modified polyurethane elastomeric waterproofing membrane for exterior below-grade or between-slab applications. It is available in four grades:

MasterSeal HLM 5000 SL (self-leveling/squeegee) MasterSeal HLM 5000 S (spray)
 MasterSeal HLM 5000 T (trowel) MasterSeal HLM 5000 R (roller)

PRODUCT HIGHLIGHTS

- Available in standard and high-build systems
- Waterproofing membrane to prevent water penetration
- Elastomeric accommodates expansion and contraction
- Wide service-temperature range, making MasterSeal HLM 5000 suitable for all climates
- Chemical resistance to bacterial attack, select acids, alkalis and salts
- Seamless cold-applied membrane eliminates lapping, seaming and precutting
- Does not require hot-melt equipment

APPLICATIONS

- Concrete
- Plywood (exterior)
- Exterior below grade (on masonry, concrete, and incidental metal)
- Above grade (between two-course concrete and within cavity walls)
- Parking garages and concrete tanks
- Plaza decks and malls
- Fountains and pools
- Balconies and planters
- Below-grade slabs
- Walls and culverts
- Sea walls, dams and reservoirs

PACKAGING

- MasterSeal HLM 5000 SL, HLM 5000 S, and HLM 5000 R: 5 gal (18.95 L) pails, 55 gal (208 L) drums; available special order
- MasterSeal HLM 5000 T: 5 gal (18.95 L) pails
- MasterSeal 995: 300 ft by 37½" (91 by 0.9 m) rolls, yielding 937 ft² (87 m²)
- MasterSeal 977:
 - 50 mil by 40" by 48" (1.3 mm by 1 m by 1.2 m) sheets, 500 per pallet, yielding 13½ ft² (1.2 m²) per sheet or 6,665 ft² (619 m²) per pallet.
 - 120 mil (½") by 40" by 48" (3 mm by 1 m by 1.2 m) sheets, 500 per pallet, yielding 13½ ft² (1.2 m²) per sheet or 6,665 ft² (619 m²) per pallet.

HOW TO APPLY MASTERSEAL HLM 5000 SURFACE PREPARATION

1. For best results, all concrete deck surfaces should be lightly steel troweled to a flat, uniform surface. A light broom finish is acceptable. New concrete must be properly water cured at least 14 days. Membrane curing compounds must be mechanically removed.

Technical Data Composition

MasterSeal HLM 5000 is a bitumen-modified polyurethane.

Compliances

- ASTM C 836
- National standard of Canada 37.58 - M86 developed by CGSB

Typical Properties

HLM 5000

PROPERTY	VALUE
Minimum recovery, %	90
Swelling in water, 3 days at room temperature	Nil
Service temp. range, °F (°C)	
Minimum	-40 (-40)
Maximum	120 (49)
MASTERSEAL 995	
PROPERTY	VALUE
Width, in	
Minimum	37 1/2
Maximum	38 1/2
Length, ft	300
Thickness, in	(FTM-5136) 0.024 (-0.0, + 0.002)
Nominal weight, oz/lyd²	2.13
Construction, in²	34 by 30
Yarn denier	70

Test Data

HLM 5000 (self-leveling grade)

PROPERTY	RESULTS		TEST METHOD
	High-Build System	Standard System	
Hardness, Shore OO	N/A	85	ASTM C 836
Viscosity, poise			Brookfield
HLM 5000 SL	125		
HLM 5000 S	450		
HLM 5000 R	800		
HLM 5000 T	4,000		
Tensile strength, psi (MPA)	200 (1.4)	150 (1.0)	ASTM D 412
Average elongation, %	300 ¹	600	ASTM D 412
100% modulus, psi (Mpa)	80 (0.6)	80 (0.6)	ASTM D 412
Moisture-vapor permeability, dry perms	0.075	0.1	ASTM E 96
Crack bridging test, cycled 10 times per 24 hours at - 15 °F (- 26 °C)	Passed ¼"; no loss of bond or cracking exhibited	Passed ⅛"; no loss of bond or cracking exhibited	ASTM C 836
Extensibility after heat aging		No cracking	ASTM C 836
Adhesion in peel, lbs/in (1 lb/in minimum)	5		ASTM C 836
Weight loss, % (20% max)		16	ASTM C 836

Results shown are typical but are not intended as performance criteria for on-site installed material.
¹Tested in direction of greatest elongation of fabric

MasterSeal 995

PROPERTY	RESULTS	TEST METHOD
Elongation, %		ASTM 5034
Machine direction	54	
Cross direction	147	
Grab breaking, lbs		ASTM 5034
Machine direction	54	
Cross direction	32	
Mullen burst, psi	70	

MasterSeal 977

PROPERTY	RESULTS	TEST METHOD
Weight, lbs/ft²		
50 mil	0.188	
120 mil	0.428	
Burst strength, psi (MPa)	175	ASTM D 2529
Puncture resistance, in-lbs	45	ASTM D 781

Test results are averages obtained under laboratory conditions. Reasonable variations can be expected.

MASTERSEAL 976

CORE		FABRIC	
Compressive Strength (ASTM D-1621)	21,000 psf 1005 kNm ²	Flow (ASTMD-4491)	60 gpm/ft ² 2460 lpm/m ²
Thickness (ASTM D-1777)	.40 in 1.016 cm		
Flow (Hydraulic gradient = 1) (ASTM D-4716)	23 gpm/ft width 286 lpm/m width		

MASTERSEAL 975

CORE		FABRIC	
Compressive Strength (ASTM D-1621)	15,000 psf (719 kNm ²)	Flow (ASTMD-4491)	140 gpm/ft ² (5704 lpm/m ²)
Thickness (ASTM D-1777)	.40 in (10.16 mm)		
Flow (Hydraulic gradient = 1) (ASTM D-4716)	21 gpm/ft width (260 lpm/m width)		

MASTERSEAL 974

CORE		FABRIC	
Compressive Strength (ASTM D-1621)	11,000 psf (528 kNm ²)	Flow (ASTMD-4491)	140 gpm/ft ² (5704 lpm/m ²)
Thickness (ASTM D-1777)	.40 in (10.16 mm)		
Flow (Hydraulic gradient = 1) (ASTM D-4716)	18 gpm/ft width (223 lpm/m width)		

2. For extremely porous block: Prime with a coat of MasterSeal HLM 5000 diluted up to 25% with MasterSeal 990 or xylene. Or apply a parge coat of MasterSeal 581 at the rate of approximately 400 ft² (37.2 m²) per bag and allow to cure a minimum of 7 days before applying MasterSeal HLM 5000.
3. Remove dust, dirt and other contaminants just before or during application. Surfaces must be dry at the time of application.
4. Air-void pockmarks or honeycombs must be opened up to allow MasterSeal HLM 5000 to fill the cavities completely. Air entrapment within voids may cause blisters. Extreme cases may require additional repair.

PRESTRIPING

1. Before applying the final membrane, all joints, cracks and openings around protrusions must be sealed by caulking or prestriping (a preliminary coating of MasterSeal HLM 5000 applied with a trowel or stiff-bristled brush). Allow to dry overnight before applying final membrane.
2. When the final membrane is applied, the overall thickness over joints and cracks, at coves and around penetrations should be approximately 100 wet mils (2.5 mm) on the standard system.

STATIC JOINTS AND CRACKS

Joints and cracks less than 1/16" (1.6 mm) should be filled by prestriping. Apply material so it both fills and overlaps the joint or crack to a width of 4" (102 mm) on each side.

WORKING OR EXPANSION JOINTS

All joints over 1/8" (3 mm) must be sealed with a Master Builders Solutions urethane sealant. Any working joint less than 1/8" (3 mm) should be routed to a minimum of 1/4" (6 mm) and filled with a sealant. Prevent the waterproofing membrane from adhering to the joint sealant, which could cause sealant or membrane failure, by applying a coat of wax or bond breaker tape over the cured sealant and then prestriping.

UNCOATED METAL SURFACES

Remove dust, debris, and any other contaminants from vent, drain pipe and post penetrations, reglets and other metal surfaces. Clean surfaces to near white per

SSPC-NACE2 and prime immediately with MasterSeal P 173. Provide appropriate cant with MasterSeal NP 1™ or NP 2™ sealants to eliminate 90° angles.

VENT, DRAIN PIPE, AND POST PENETRATIONS
Clean metal surfaces to bright metal and prime with a quality rust-inhibiting metal primer followed by MasterSeal P 173 or P 176. Remove dust, debris and any other contaminants from voids. Seal with the appropriate sealant.

APPLICATION

A test application is always recommended before proceeding with entire application.

NOTE: Finish coat must be applied in a pinhole-free, continuous membrane for waterproofing integrity.

STANDARD SYSTEM

1. Select the grade of MasterSeal HLM 5000 that best meets individual job requirements. Use MasterSeal HLM 5000 T for trowel application, MasterSeal HLM 5000 S for spray application, MasterSeal HLM 5000 R for roller application or MasterSeal HLM 5000 SL for squeegee application.
2. For horizontal applications, empty contents of pail and spread immediately to ensure workability. Best results are obtained by marking off 125 ft² (11.61 m²) areas and evenly spreading the contents of a 5 gallon (18.93 L) unit with a rubber-edged notched squeegee. Repeat the above procedure until the entire surface is covered.
3. For vertical applications, apply by trowel, roller or spray at the rate of 25 ft²/gallon (0.6 m²/L). Best results are obtained by marking off 125 ft² (11.6 m²/L) and evenly applying the contents of a 5 gallon (18.93 L) pail.
4. Verify the applied thickness with a wet mil gauge as the work progresses.
5. The integrity of the cured membrane on a horizontal surface may be verified by damming the entire area and flooding with water to a minimum depth of 2" (51 mm) and allowing the water to stand for 24–48 hours. Visually inspect the bottom surface to check for any water penetration. If repairs are necessary, the area should be drained and allowed to dry before reapplying MasterSeal HLM 5000. After reapplication, the area should be tested again for membrane integrity.

HIGH-BUILD SYSTEM

Concrete application: Apply 60 wet mils of MasterSeal HLM 5000, followed by setting MasterSeal 995 reinforcing fabric into the wet material. Overlap all seams a minimum of 3" (76 mm). Additional material may be required to properly embed the reinforcing fabric where it overlaps. Allow the first coat to cure overnight and follow with a second 60 wet-mil application of MasterSeal HLM 5000.

Plywood application: All plywood construction must comply with APA (American Plywood Association) standards. Caulk all joints with a Master Builders Solutions sealant and then proceed with the MasterSeal HLM 5000 high-build system.

SPRAY EQUIPMENT

For spray equipment recommendations, consult the equipment manufacturer.

CURING

Appreciable properties develop within 24–48 hours at 75 °F (24 °C) and 50% relative humidity. Protect MasterSeal HLM 5000 from traffic during curing.

DRAINAGE AND PROTECTION

1. For protection during backfill and where hydrostatic pressure is anticipated, use the appropriate MasterSeal 975 Drain Board System for installation instructions.
2. For protection during backfill only, install protection board as soon as possible following cure of MasterSeal HLM 5000.

CLEAN UP

Clean all tools and equipment immediately after application with MasterSeal 990.

HOW TO APPLY MASTERSEAL 977 SURFACE PREPARATION

1. Waterproofing membranes must be protected against tear, puncture, and other abuses during placement of concrete wearing slabs and reinforcing steel. They should also be protected from jobsite traffic and backfilling operations.
2. All specifications calling for membrane waterproofing should also require protection of membrane as an integral part of the overall waterproofing system.

APPLICATION

Install overlapping MasterSeal 977 protection board as soon as possible following cure of the liquid membrane. Protect MasterSeal HLM 5000 from traffic before placement of protection board. MasterSeal HLM 5000 must be cured before installation of any topping.

FOR BEST PERFORMANCE

MASTERSEAL HLM 5000

- Apply MasterSeal HLM 5000 when substrates are dry and air temperatures are 40 to 90 °F (4 to 32 °C); for application at temperatures below 40 °F (4 °C), consult Technical Services.
- Temperatures influence viscosity and handling characteristics of MasterSeal HLM 5000: heat increases and cold decreases the flow. Keep MasterSeal HLM 5000 cool in hot weather and warm in cold weather.
- Avoid application when inclement weather is present or imminent.
- Do not apply to reinforcing bars or to wet or contaminated surfaces.
- Do not directly heat containers with flame, stove, hot plate or oven.
- Patch all voids and deep depressions in substrates with appropriate patching material before applying MasterSeal HLM 5000.
- Use MasterSeal 550 under thin-set tile applications.
- Before applying MasterSeal HLM 5000, dam all drains and drain openings.
- Carefully work material over irregular concrete to avoid pinholes and holidays.
- Protect MasterSeal HLM 5000 coated surfaces from puncture with protection board until required topping or backfill is placed.
- Not intended as an exposed or wearing surface.
- Do not use where a solvent odor is objectionable, e.g., near areas where food preparation or processing occur during the application.
- Specify wet or paper curing for concrete to be coated with MasterSeal HLM 5000; avoid using liquid curing compounds.
- In horizontal applications concrete must be sloped to drain to avoid ponding water on the surface of MasterSeal HLM 5000
- When using drainage mat directly over MasterSeal HLM 5000, a layer of 6 mil

polyethylene sheeting should be used between the MasterSeal HLM 5000 and the drainage mat.

MASTERSEAL 977

- Store MasterSeal 977 on a flat surface and keep it dry; do not remove shrink wrap until immediately before use.
- If board is exposed to prolonged periods of water immersion or excessive humidity, it may curl or wrinkle.
- MasterSeal 977 to be covered with a concrete wearing course must be securely attached to membrane.

GENERAL

- Proper application is the responsibility of the user. Field visits by Master Builders Solutions personnel are for the purpose of making technical recommendations only and not for supervising or providing quality control on the jobsite.

HEALTH, SAFETY AND ENVIRONMENTAL

Read, understand and follow all Safety Data Sheets and product label information for this product prior to use. The SDS can be obtained by visiting www.master-builders-solutions.com/en-us, e-mailing your request to mbsbscst@mbcc-group.com or calling 1(800)433-9517. Use only as directed.

IN CASE OF EMERGENCY: Call CHEMTEL +1 (800) 255-3924 or if outside the US or Canada, +1 (813) 248-0585.

LIMITED WARRANTY NOTICE

Master Builders Solutions Construction Systems US, LLC ("Master Builders") warrants this product to be free from manufacturing defects and to meet the technical properties on the current Technical Data Guide, if used as directed within shelf life. Satisfactory results depend not only on quality products but also upon many factors beyond our control. MASTER BUILDERS MAKES NO OTHER WARRANTY OR GUARANTEE, EXPRESS OR IMPLIED, INCLUDING WARRANTIES OF MERCHANTABILITY OR FITNESS FOR A PARTICULAR PURPOSE WITH RESPECT TO ITS PRODUCTS. The sole and exclusive remedy of Purchaser for

any claim concerning this product, including but not limited to, claims alleging breach of warranty, negligence, strict liability or otherwise, is shipment to purchaser of product equal to the amount of product that fails to meet this warranty or refund of the original purchase price of product that fails to meet this warranty, at the sole option of Master Builders. Any claims concerning this product must be received in writing within one (1) year from the date of shipment and any claims not presented within that period are waived by Purchaser. MASTER BUILDERS WILL NOT BE RESPONSIBLE FOR ANY SPECIAL, INCIDENTAL, CONSEQUENTIAL (INCLUDING LOST PROFITS) OR PUNITIVE DAMAGES OF ANY KIND.

Purchaser must determine the suitability of the products for the intended use and assumes all risks and liabilities in connection therewith. This information and all further technical advice are based on Master Builders' present knowledge and experience. However, Master Builders assumes no liability for providing such information and advice including the extent to which such information and advice may relate to existing third party intellectual property rights, especially patent rights, nor shall any legal relationship be created by or arise from the provision of such information and advice. Master Builders reserves the right to make any changes according to technological progress or further developments. The Purchaser of the Product(s) must test the product(s) for suitability for the intended application and purpose before proceeding with a full application of the product(s). Performance of the product described herein should be verified by testing and carried out by qualified experts.

FOR PROFESSIONAL USE ONLY. NOT FOR SALE TO OR USE BY THE GENERAL PUBLIC

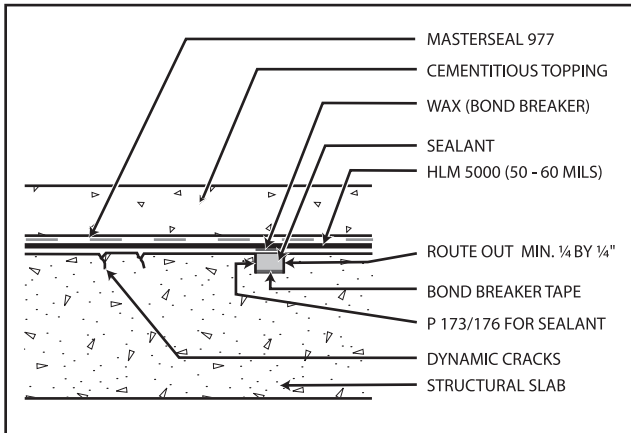

Dynamic Crack Detail

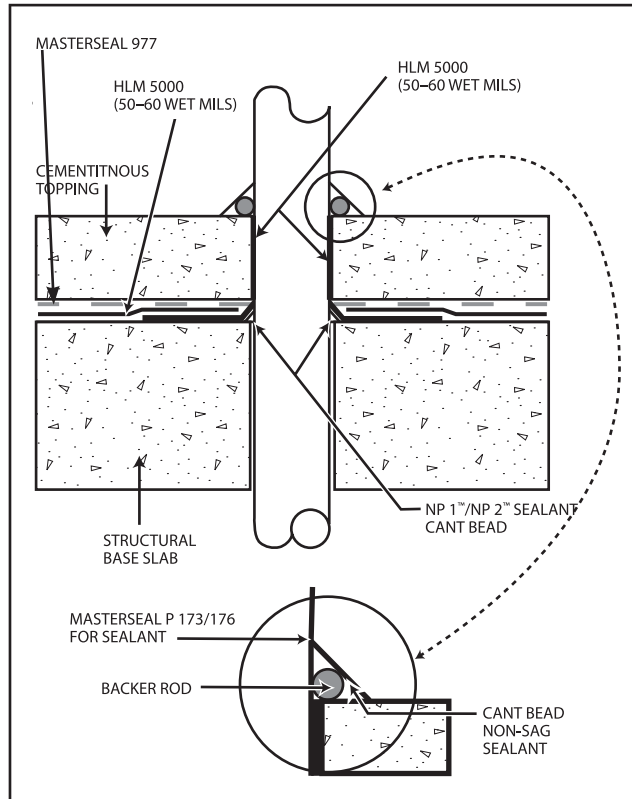

Vent/Drain/Pipe/Post Penetration Detail

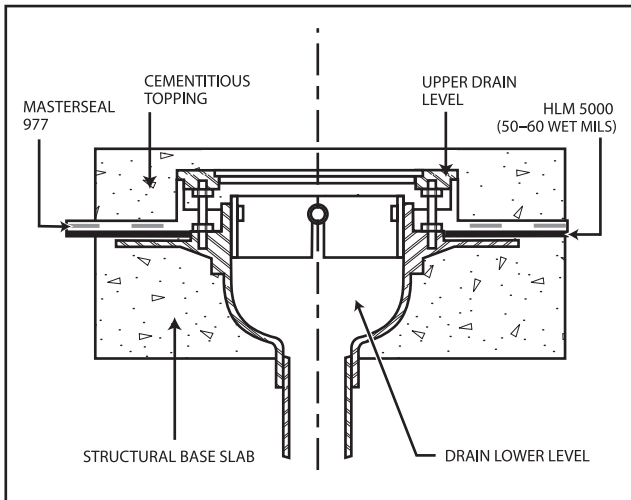

Waterproofing at Bi-Level Drain

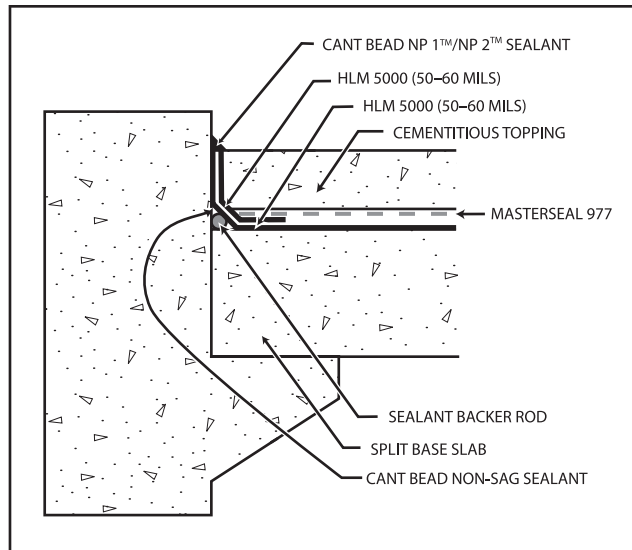

Split Slab with Cant Detail

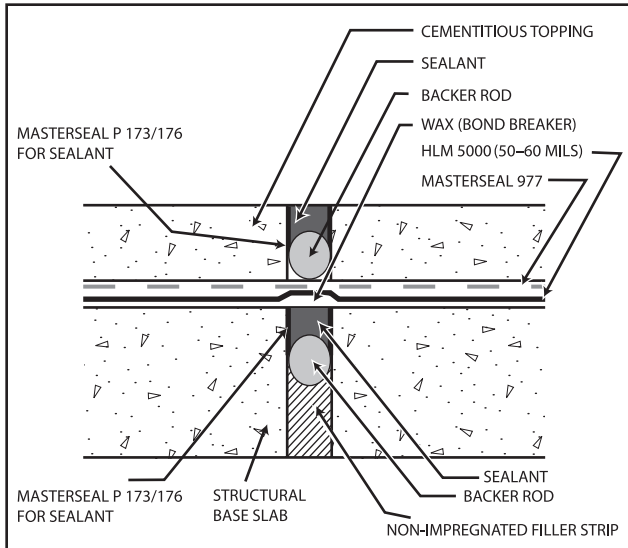

Expansion Joint Detail

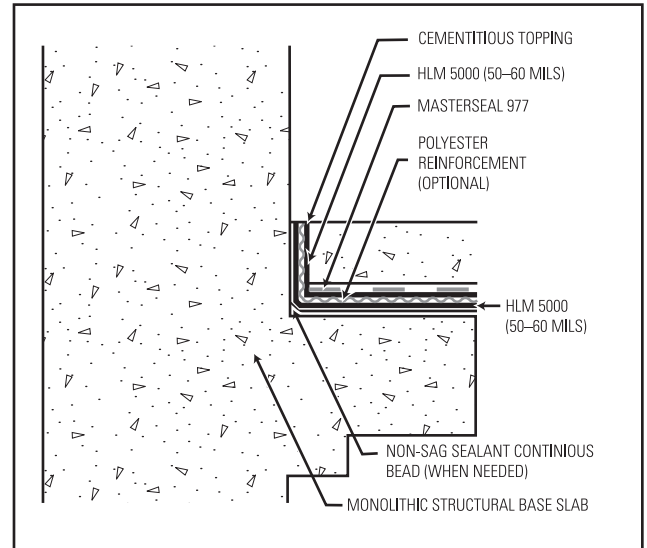

Inside Corner Detail (Static)

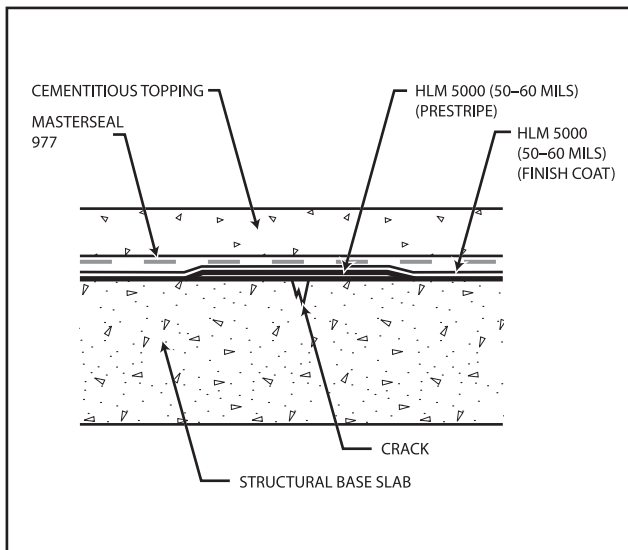

Static Crack/Prestripe Detail

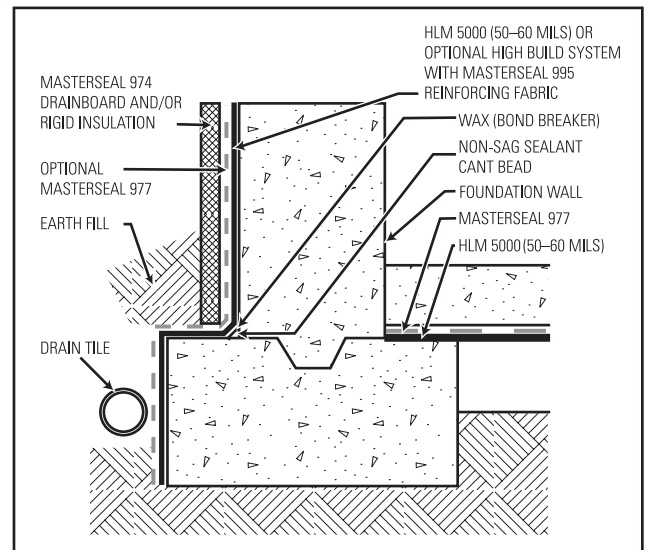

Waterproofing Foundation Walls